

# AKIRA

makes life better

---

## Air Conditioner Service Manual



Большая библиотека технической документации

<https://splitsystema48.ru/instrukcii-po-ekspluatacii-kondicionerov.html>

каталоги, инструкции, сервисные мануалы, схемы.

# **MODEL: AC-W13CG**

---

Model No.: AC-W13CG  
Version: 1.0

---

## CONTENTS

TECHNICAL SPECIFICATION.....	4
PERFORMANCE CURVE .....	5
OUTLINE & DIMENSIONS .....	6
EXPLODED VIEW & PARTLIST.....	7
CIRCUIT DIAGRAM .....	9
PCB FUNCTION MANUAL.....	10

## TECHNICAL SPECIFICATION

Content		AC-W13CG
Function		Cooling
Power supply		1Ph 220~230V-50Hz
Capacity	(W)	3200
	(BTU/h)	10922
Rated input (W)		1390
Rated current (A)		6.5
Air flow (m <sup>3</sup> /h)		430
Dehumidifying volume (L/h)		1.6
EER(W/W)		2.4
Indoor side	Fan type/piece	Centrifugal fan-1
	Diameter-length(mm)	217mm x 90
	Evaporator	Aluminum fin-copper tube
	Row-fin distance(mm)	2-14
	Working area(m <sup>2</sup> )	0.11
	Swing motor	SM002
	Input(W)	4
	Fuse (A)	Controller 3.15A
	Working capacitor (μ F)	3.5 μ F/450V
	Noise(dB(A))	51
Outdoor unit	Compressor Model	C-RV222H1AA
	L.R.A. (A)	31
	Throttling method	Capillary
	Starting method	Capacity starting
	Working temp.	≤115°C
	Condenser	Aluminum fin-copper tube
	Pipe-diameter	9.52
	Row-fin distance (mm)	2-1.8
	Working area	0.16
	Type-piece	Axial fan-5
	Noise (dB(A))	57
Diameter	325	
Defrosting method	Auto defrosting	
Motor fan speed (rpm)		970/900/850
Output power (W)		60
Dimension (W x H x D) (mm)		570 x 380 x 590
Net weight (kg)		45
Refrigerant charge		R22/670g

## PERFORMANCE CURVE

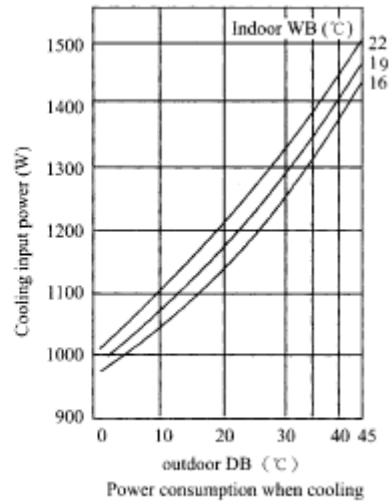
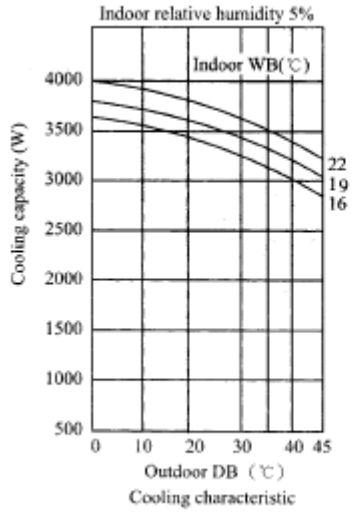

## OUTLINES AND DIMENSIONS

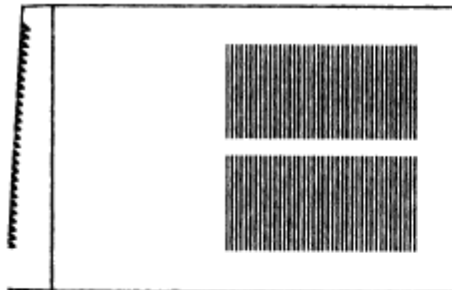

(a)

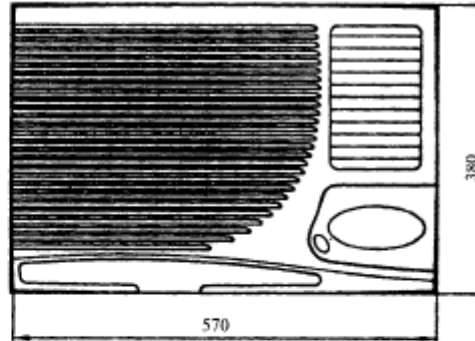

(b)

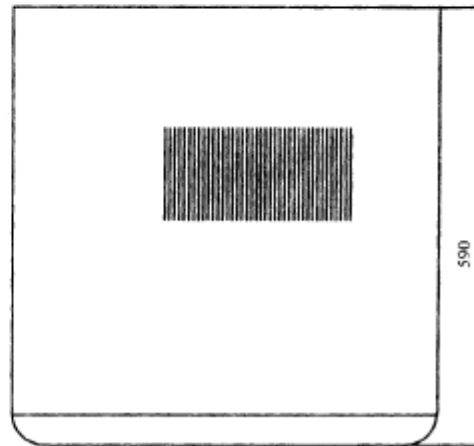

(c)

## EXPLODED VIEW & PART LIST

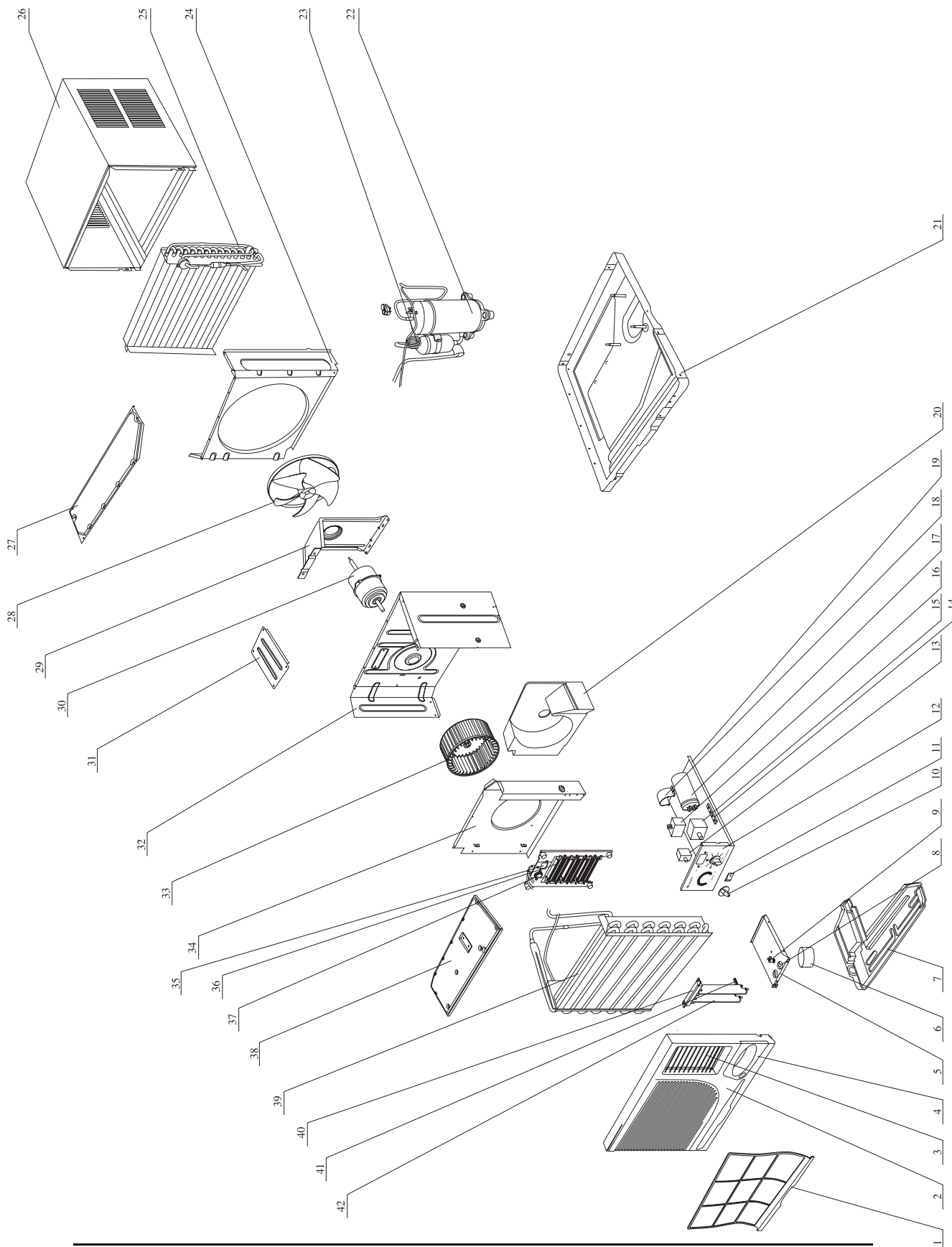

Model No.: AC-W13CG  
Version: 1.0

No.	Part name	Qty
1	Fliter net	1
2	Front panel	1
3	Horizontal air guider	1
4	Cover of switch	1
5	base plate	1
6	Swing motor	1
7	Drain pan	1
8	Plug	2
9	Slide block	1
10	Knob	2
11	Swing switch	1
12	Mask	1
13	Thermostat	1
14	Insulating gasket D	1
15	Main switch	1
16	fan capacitor	1
17	Compressor capacitor	1
18	Capacitor clamp	1
19	Electric box	1
20	Propeller housing	1
21	Chassis assembly	1
22	Compressor	1
23	Capillary assembly	1
24	Rear insulation plate	1
25	Condencer	1
26	Cabinet	1
27	Top cover of condensor	1
28	Axial flow fan	1
29	Motor support	1
30	Motor	1
31	Top connection plate	1
32	front insulation plate	1
33	Centrifugual fan	1
34	insulation plate of housing	1
38	Top cover of evaporator	1
39	Evaporator	1
40	Cross beam	1
41	connecting lever	1
42	Air guider	2
	Power cord	1



## CIRCUIT DIAGRAM

These circuit diagrams are subject to change without notice. Please refer to the ones stuck on the machines.

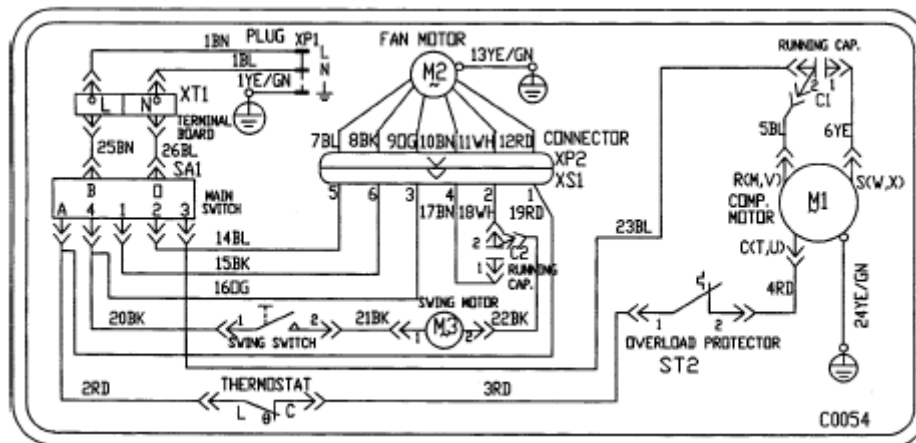

## PCB FUNCTION MANUAL

### A. Running mode

1. Cool
2. Dry
3. Fan
4. Heat
5. Auto
6. Manual operation

### B. Controlling contents

1. Indoor unit fan motor (high, middle and low speed)
2. Compressor
3. Sweep fan motor
4. Buzzer
5. Reversing valve
6. Electrical heater

### C. The parameter to be input

1. The set mode
2. The set temperature of the indoor (shorten form is Test)
3. The set speed
4. The mode of timer
5. The ambient temperature of the indoor unit (shorten form is Tin)
6. The temperature of the defrosting sensor (shorten form is Tde)
7. The sweep mode

### D. The basal control modes

#### Cooling mode

- 1 If  $T_{in} \geq T_{set} + 1^{\circ}\text{C}$  cooling mode act, compressor run, unit fan motor and sweep fan motor run in the set speed, reversing valve stop.
- 2 If  $T_{in} \leq T_{set} - 2^{\circ}\text{C}$  compressor stop, unit fan motor and sweep fan motor run in the set speed.
- 3 If  $T_{set} - 2^{\circ}\text{C} < T_{in} < T_{set} + 1^{\circ}\text{C}$  keep running in the old mode.
- 4 In the cooling mode, the range of  $T_{set}$  is  $16^{\circ}\text{C} \sim 30^{\circ}\text{C}$  and it can be set in CON.
- 5 Compressor restart in 3 min after the unit stop and won't stop during the following 6 min because  $T_{in}$  and  $T_{set}$ .

#### Drying mode

- 1 If  $T_{in} > T_{set}$ , drying mode act.
- 2 If  $T_{in} < T_{set}$  drying mode stop, compressor stop, unit fan motor run in low speed.
- 3 If  $T_{in} \leq T_{set} - 2^{\circ}\text{C}$ , compressor and fan motor stop.
- 4 Unit fan motor run for 6 min in low speed, compressor stop, fan motor run in low speed. After 4 min, unit fan motor running low speed for 6min. Then run by this cycle.
- 5 In drying mode, the range of  $T_{set}$  is  $18^{\circ}\text{C} \sim 30^{\circ}\text{C}$  and it can be set in CON.
- 6 The protecting functions are same as cooling mode.

**Fan mode**

- 1 Unit fan motor can run in high, middle, low and auto speed, compressor stop.
- 2 If the different in temperature of  $T_{in}$  and  $T_{set}$  is 2~4°C, motor run in middle speed.
- 3 If the different in temperature of  $T_{in}$  and  $T_{set}$  is less than 2°C, motor run in low speed.
- 4 If the different in temperature changed, fan speed will change when the new difference is more or less 1°C than the old one.
- 5 In drying mode, the range of  $T_{set}$  is 18°C ~ 30°C and it can be set in CON.
- 6 There is no protection mode in fan mode.

**Heating mode**

- 1 If  $T_{in} \leq T_{set} - 1^\circ\text{C}$ , heating mode act, reversing, compressor run, unit fan motor run in the set speed and the condition of avoiding the cold wind, sweep fan motor run in the set mode.
- 2 If  $T_{in} \geq T_{set} + 2^\circ\text{C}$ , compressor stop, reserving valve is still electric then unit fan motor run in the low speed.
- 3 If  $T_{set} < T_{in} < T_{set} + 2^\circ\text{C}$ , keep running in the old mode.
- 4 4-way valve stop in 4 min after unit stop.
- 5 When heating time exceed 45 min and  $T_{de} \leq -8^\circ\text{C}$ , defrosting mode act reversing valve and fan motor stop, compressor still run.
- 6 When defrosting time exceed 8 min and  $T_{de} \geq +10^\circ\text{C}$ , defrosting stop, heating mode act. Reversing valve run, fan motor run in the set speed and condition of avoiding cold wind.
- 7 Once heating mode act, and fan motor run in high or middle speed, electrical heater work and it won't work when fan motor run in low speed.
- 8 In heating mode, the range of  $T_{set}$  is 16°C ~ 30°C or it can be set in CON.
- 9 The conditions of avoiding cold wind, fan motor run in 30sec after compressor start.
- 10 The protection of compressor's delay. Compressor restart in 3min later after it stop and won't stop in the following by  $T_{in}$  and  $T_{set}$ .

**AUTO mode**

- 1 If  $T_{in} \geq T_{set} + 1^\circ\text{C}$ , cooling mode act,  $T_{set} = 26^\circ\text{C}$  unit fan motor run in set speed.  
If  $T_{in} \leq T_{set} - 2^\circ\text{C}$ , compressor stop and fan motor run in low speed.  
If  $T_{set} + 2^\circ\text{C} < T_{in} < T_{set} + 1^\circ\text{C}$  the unit run in old mode.
- 2 If  $T_{in} \leq T_{set}$ , heating mode act  $T_{set} = 20^\circ\text{C}$ . If  $T_{in} \geq T_{set} + 3^\circ\text{C}$ , compressor and reversal valve stop, unit fan motor run in low speed. If  $T_{set} < T_{in} < T_{set} + 3^\circ\text{C}$ , keep the old mode.
- 3 Press  $\Lambda$  or  $V$  to change  $T_{set}$  1 ~ 2°C more or less.

**Protection function**

They are same as the protection functions of cooling or heating mode.

If  $T_{in}$  change, mode change first. There is no protection of compressor that compressor won't stop in the following 6 min once it run.

**Others control**

- 1 Timer
- 2 Manual operation
- 3 Sleep
- 4 Motor speed
- 5 Sweep motor
- 6 Running indicate light
- 7 Timer indicate light
- 8 Compressor indicate light
- 9 Buzzer



**Большая библиотека технической документации**

<https://splitsystema48.ru/instrukcii-po-ekspluatacii-kondicionerov.html>

**каталоги, инструкции, сервисные мануалы, схемы.**